



T.R. JONES MACHINE COMPANY, INC.

BASIC STYLE	STANDARD SUBLINER AND BALANCER DIMENSIONS													
	A	B	C	D	E	F	G	H	I	J	K	L	M	N
1	.4375	.440	9/16	5/16	5/32	5/16	15/32	1/4-20	3/4	1	5/8	1/2	1/8	2-1/2
2	.500	.5025	11/16	3/8	3/16	5/16	1/2	1/4-20	1	1-1/8	11/16	1/2	3/16	3
3	.5625	.565	3/4	7/16	7/32	3/8	19/32	5/16-18	1	1-1/8	3/4	5/8	1/4	3-1/2
4	.625	.6275	13/16	1/2	1/4	3/8	5/8	3/8-16	1	1-1/8	13/16	3/4	1/4	4
5	.750	.7525	15/16	1/2	1/4	7/16	11/16	3/8-16	1	1-1/8	15/16	3/4	5/16	4-1/2

SPECIALS To order non-standard pins, indicate BASIC STYLE (based on "A" dimension) on the order form below. Use print to indicate ONLY those dimensions which vary from the standard specifications reflected above.

BALANCER PIN WITH LUBRICATION

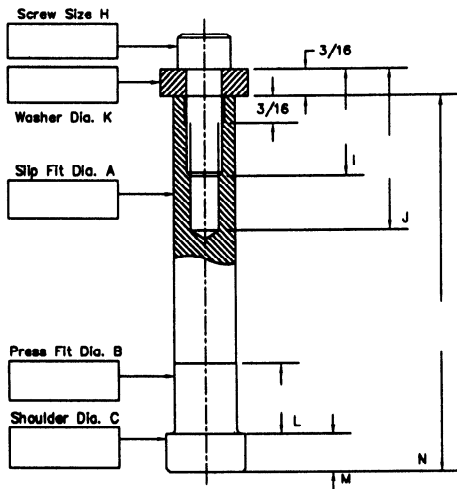

STYLE LSB1

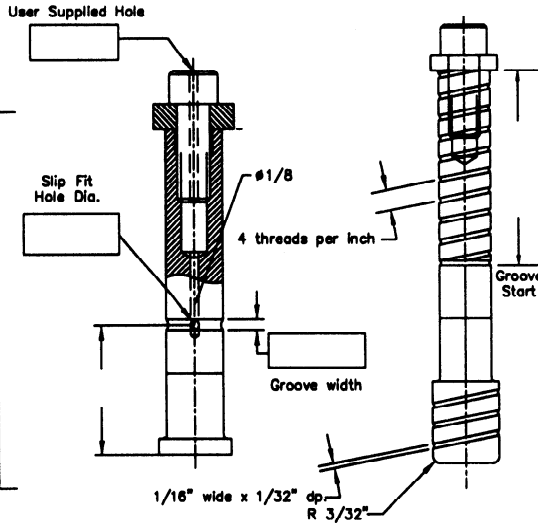

STYLE LSB2

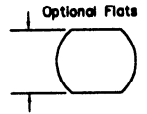

Qty.	Description	Basic Style	Material	Rockwell Number
	Balancer			
	Washer and Cap Screw			

BASIC STYLE	STANDARD SUBLINER AND BALANCER DIMENSIONS													
	A	B	C	D	E	F	G	H	I	J	K	L	M	N
1	.4375	.440	9/16	5/16	5/32	5/16	15/32	1/4-20	3/4	1	5/8	1/2	1/8	2-1/2
2	.500	.5025	11/16	3/8	3/16	5/16	1/2	1/4-20	1	1-1/8	11/16	1/2	3/16	3
3	.5625	.565	3/4	7/16	7/32	3/8	19/32	5/16-18	1	1-1/8	3/4	5/8	1/4	3-1/2
4	.625	.6275	13/16	1/2	1/4	3/8	5/8	3/8-16	1	1-1/8	13/16	3/4	1/4	4
5	.750	.7525	15/16	1/2	1/4	7/16	11/16	3/8-16	1	1-1/8	15/16	3/4	5/16	4-1/2

SPECIALS To order non-standard pins, indicate BASIC STYLE (based on "A" dimension) on the order form below. Use print to indicate ONLY those dimensions which vary from the standard specifications reflected above.

SUBLINER PIN WITH LUBRICATION

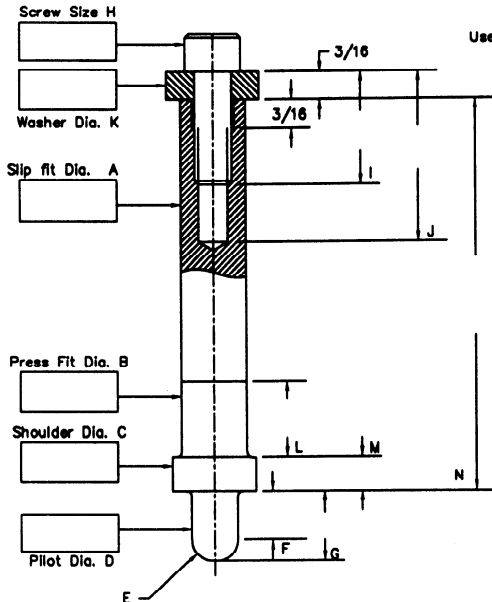

STYLE LS1

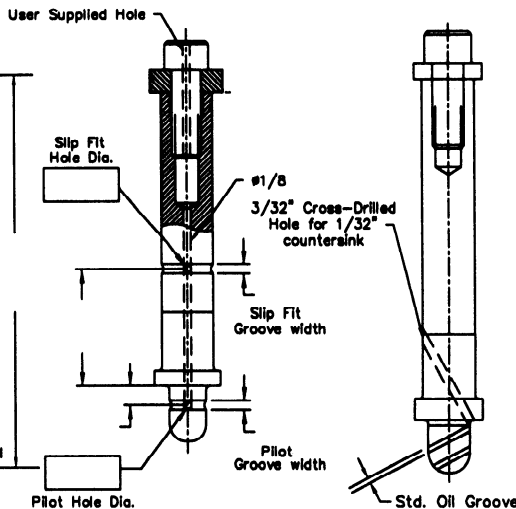

STYLE LS2

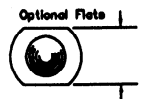

Qty.	Description	Basic Style	Material	Rockwell Number
	Sub-Liner			
	Washer and Cap Screw			

* Balancer Pin with Lubrication Reverse Side